

VP Minor S.S



VP Minor Bronze



Description

Tank Washing is a vital part of a ships operations and it is essential that the equipment on board is robust, reliable and fit for purpose. Victor Marine bring with them a long tradition of supplying reliable and efficient equipment and can offer both twin and single nozzle machines which offer a solution to all tank washing problems.

The VP Minor is a pre-programmed twin nozzle tank washing machine available in both 316 stainless steel and bronze. This unit is suitable for use on small and medium sized crude oil, chemical and product tankers supplied either for fixed and portable applications.

Typical installation

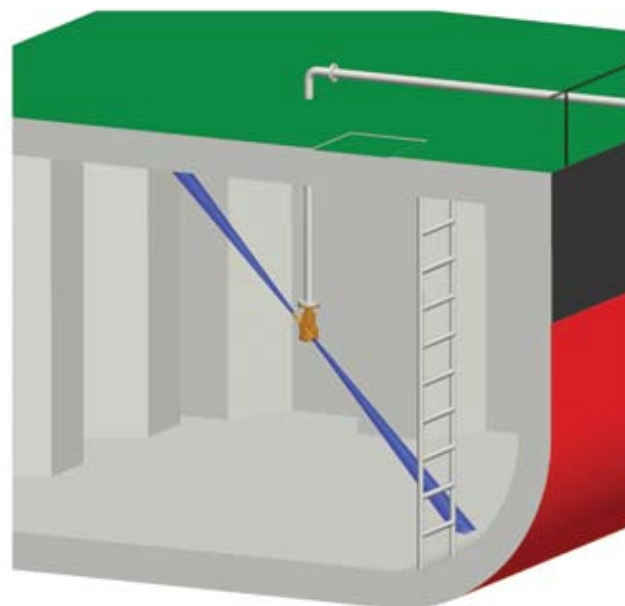

Key features

- ▶ Wash pattern is of Orbital progressive intensity wash pattern to meet IMO Annex II pre wash requirement
- ▶ Nozzle sizes from 6mm to 11mm
- ▶ Offered with either 'sealed for life' or Media lubricated drive to ensure no cargo contamination
- ▶ Complete with automatic 'slip-clutch' to prevent accidental damage in use
- ▶ Simple to service, quick removal gear assembly with use of hi-performance long life gears
- ▶ Alternative flange (up to 160mm Diameter) and fixings available
- ▶ Available with 'Bumper Rubbers' to prevent damage to tank coating
- ▶ Sealed unit available for use in corrosive mud tanks
- ▶ Fully Type Approved by Class Societies Worldwide

TECHNICAL SPECIFICATION

Supply Pressure kg/cm ²	NOZZLE DIAMETERS														
	2x7mm			2x8mm			2x9mm			2x10mm			2x11mm		
	Flow m ³ /hr	Jetlength mtrs	Cycle Time mins	Flow m ³ /hr	Jetlength mtrs	Cycle Time mins	Flow m ³ /hr	Jetlength mtrs	Cycle Time mins	Flow m ³ /hr	Jetlength mtrs	Cycle Time mins	Flow m ³ /hr	Jetlength mtrs	Cycle Time mins
6	7.3	9.6	27	10	10	26	10.4	10.6	27	13	11.6	26	15	12.6	24
8	8	10.3	21	11.3	10.8	20	11.6	11.3	23	14.2	12.4	22	16.2	13.3	20
10	8.5	11	18.5	12.2	11.5	18	12.6	12	19	16	13	20	17.7	14	18
12	9.2	11.6	18	13	12.1	17	13.7	12.6	16	17.6	13.5	18	19.3	14.6	17

General arrangement

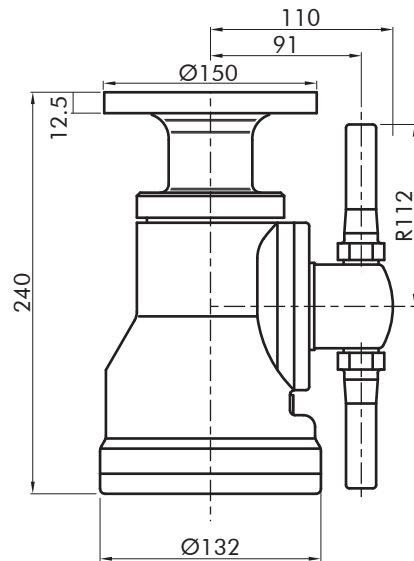

Design service

Our Engineering Department offers a full design service including product selection and shadow diagrams prior to installation

Wash pattern

Pre-programmable Rotary 360°

Jet length

Maximum: 14.6mtrs (78ft)
Typical: 9-14mtrs (30-46ft)

Operating Pressure

Maximum: 12 kg/cm² (190 psi)
Optimum: 5-10kg/cm² (72-145 psi)

Flow Capacity

Minimum: 7 m³/hr (35 US gal/min)
Maximum: 19 m³/hr (84 US gal/min)

Wash Cycle

Time: Variable on supply pressure
Typical: Between 16-30 mins
Type: 4 cycles for complete wash

Operating temperature

Maximum: 95° C (203° F)

Lubrication

Via wash media or sealed grease lubricated gearbox

Installation

Min deck opening: Ø 200mm (8.0 inches)
Fixed flanged: Std DIN 40 NP10
(Ø150mm with 4x14mm holes on a 110 PCD)
Portable: 1 1/2" BSP Male thread

Weight

Fixed flanged: 10.2 kgs (22.5 lbs)
Portable: 8.2 kgs (18.1 lbs)

Ancillary equipment available

Layflat and Rigid Hoses, Ducting, Various Fittings and Adaptors, Transport Trolley.

Please see separate information sheet for details.